

Lectures

Circuits and Electronics

Department of Petroleum and Gas

Engineering

(2nd year ,Semester II)

By

Lecturer: Suroor Moaid Dawood

Chapter One

Measuring Instruments

Introduction

Electrical instruments help us to measure the changes in variables such as voltage, current and resistance. The voltmeter is the instrument used to measure voltage; the ammeter is the instrument used to measure current; and the ohmmeter is the instrument used to measure resistance. It is common these days to have the three instruments combined into one instrument known as a multi meter, which may be analog or digital. An analog meter is one that uses a needle and calibrated meter to display the measured value; that is, the measured value is indicated by the pointer of the meter. A digital meter is one in which the measured value is shown in form of a digital display. The digital meters are more commonly used today.

Figure.1. illustrates a typical analog multimeter (combining voltmeter, ammeter, and ohmmeter) and a typical digital multimeter. The digital multimeter (DMM) is the most widely used instrument.



(a)



(b)

(a) Analog multimeter; (b) digital multimeter.

Voltmeter and Ammeter: To measure voltage (A potential difference (p.d.) of 1 volt (V) exists between two points if 1 joule (J) of energy is exchanged in moving 1 coulomb (C) of charge between the two points), we connect the voltmeter/multimeter across the element for which the voltage is desired, as shown

in Fig.2. The voltmeter measures the voltage across the load and is therefore connected in parallel with the element.

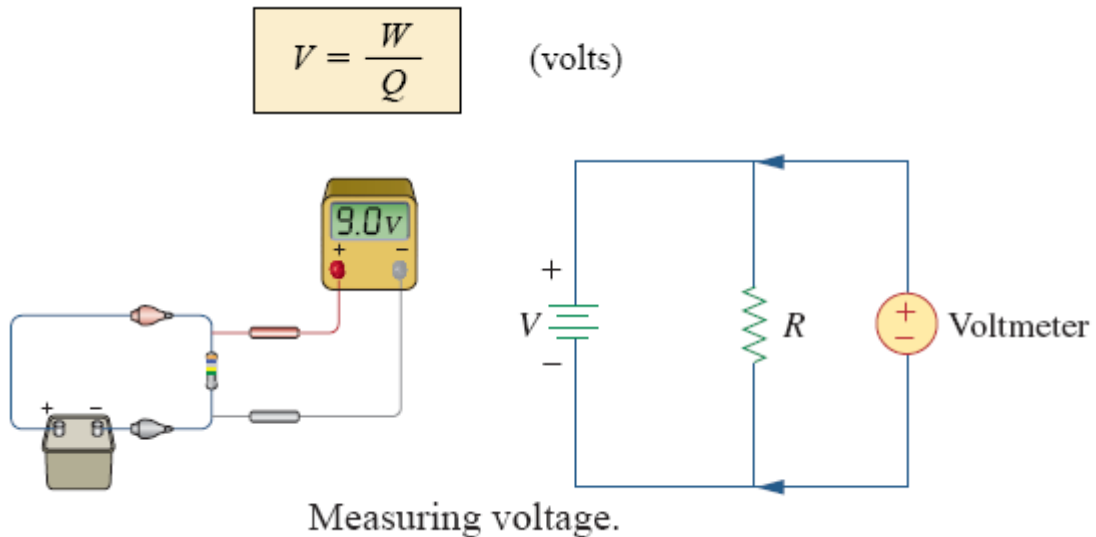

To measure current (which is the time rate of change of charge, measured in ampere),

$$I = \frac{Q}{t}$$

$I = \text{amperes (A)}$
 $Q = \text{coulombs (C)}$
 $t = \text{seconds (s)}$

we connect the ammeter/multimeter in series with the element under test, as shown in Fig. 3. The meter must be connected such that the current enters through the positive terminal to get a positive reading. The circuit must be “broken”; that is, the current path must be interrupted so that the current must flow through the ammeter. (The clampmeter is another device for measuring ac current.)

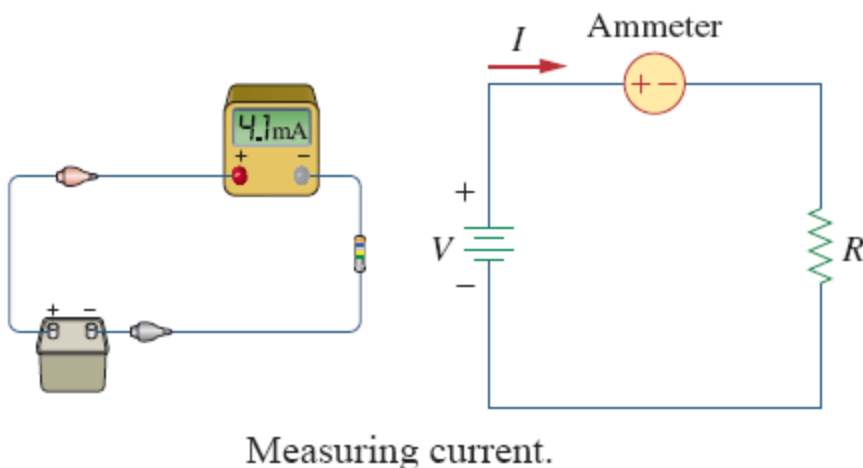

Ohmmeter

To measure resistance (The flow of charge through any material encounters an opposing force similar in many respects to mechanical friction. This opposition, due to the collisions between electrons and between electrons in other atoms of the material, which converts electrical energy into another form of energy such as heat, is called the **resistance** of the material. The unit of measurement of resistance is the **ohm**, for which the symbol is Ω)of an element, connect the ohmmeter/multimeter across it, as shown in Fig. 4. If the element is connected to a circuit, one end of the element must first be disconnected from the circuit before we measure its resistance. If the wire has a break, the ohmmeter connected across it will read infinity. Thus, the ohmmeter can be used to detect a short circuit (low resistance) and an open circuit (high resistance).

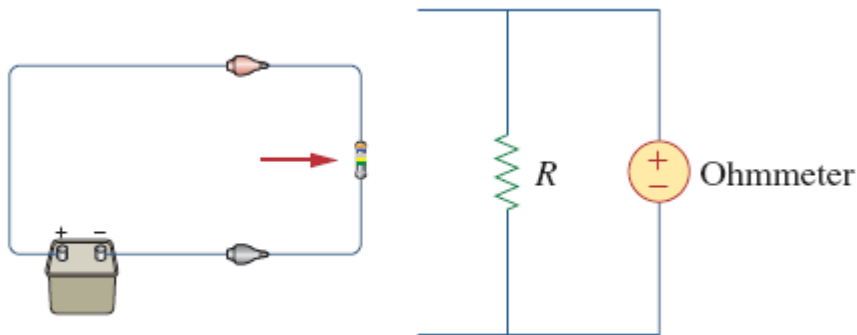

Measuring resistance.

$$I = \frac{E}{R} \quad (\text{amperes, A})$$

$$E = IR \quad (\text{volts, V})$$

$$R = \frac{E}{I} \quad (\text{ohms, } \Omega)$$

When working with any of the meters mentioned in this section, it is good practice to observe the following:

1. If possible, turn the circuit power off before connecting the meter.
2. To avoid damaging the instrument, it is best to always set the meter on the highest range and then move down to the appropriate range.
3. When measuring dc current or voltage, observe proper polarity.

4. When using a multimeter, make sure you set the meter in the correct mode (ac, dc, V, A, Ω).
5. When the measurement is completed, turn off the meter to avoid draining the internal battery of the meter. This leads to the issue of safety in electrical measurement.

Wattmeter

The wattmeter is an instrument for measuring the electric power (which is a *rate* of doing work) in watts of any given circuit. The connections of a wattmeter are shown in Fig.5. The fixed circular coil which carries the main circuit current I_1 is wound in two halves positioned parallel to each other. The moving coil which is pivoted centrally carries a current I_2 which is proportional to the voltage V . The equivalent diagrammatic view is shown in Fig. 6.

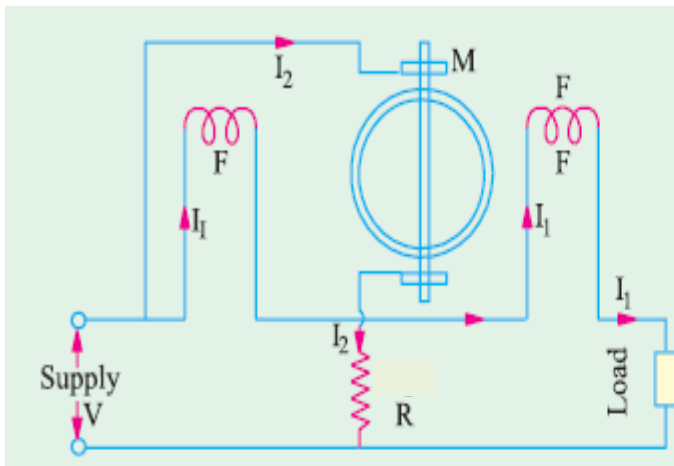

Fig.5.

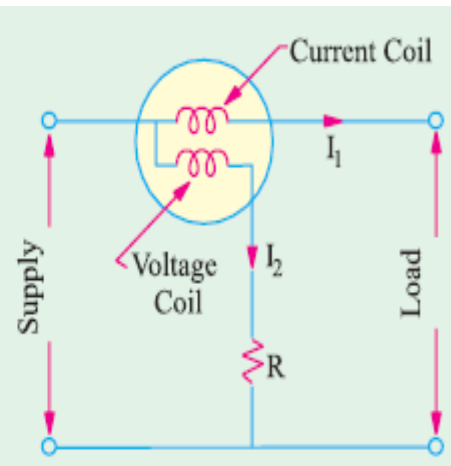

Fig.6.

1 watt (W) = 1 joule/second (J/s)

$P = \frac{W}{t}$ (watts, W, or joules/second, J/s)

$P = VI$ (watts)

$P = \frac{V^2}{R}$ (watts)

$P = I^2R$ (watts)

